



INSTALLATION MANUAL

RTV KEYLESS START (77700-10657 & 77700-10658)

KUBOTA RTV-XG850, RTV-X900, RTV-X1100C, RTV-X1120, RTV-X1140

CALIFORNIA PROPOSITION 65

⚠ WARNING:

Cancer and reproductive harm - www.P65Warnings.ca.gov

BEFORE INSTALLING RTV KEYLESS START

- Read all instructions and safety instructions in this manual.
- Refer to your machine's operator's manual and safety instructions on your machine's safety decals.
- Wear appropriate personal protective equipment (PPE) when performing work.
- Disconnect negative (-) terminal on battery before performing work.
- Hang a "DO NOT OPERATE" tag in operator station.

⚠ WARNING

To avoid personal injury or death:



- Shut off machine and disconnect negative (-) terminal before working on the electrical circuit.
- Do not short circuit the battery, starter motor or electrical circuits.

■ CHECKING PARTS

[For RTV Keyless Start System]

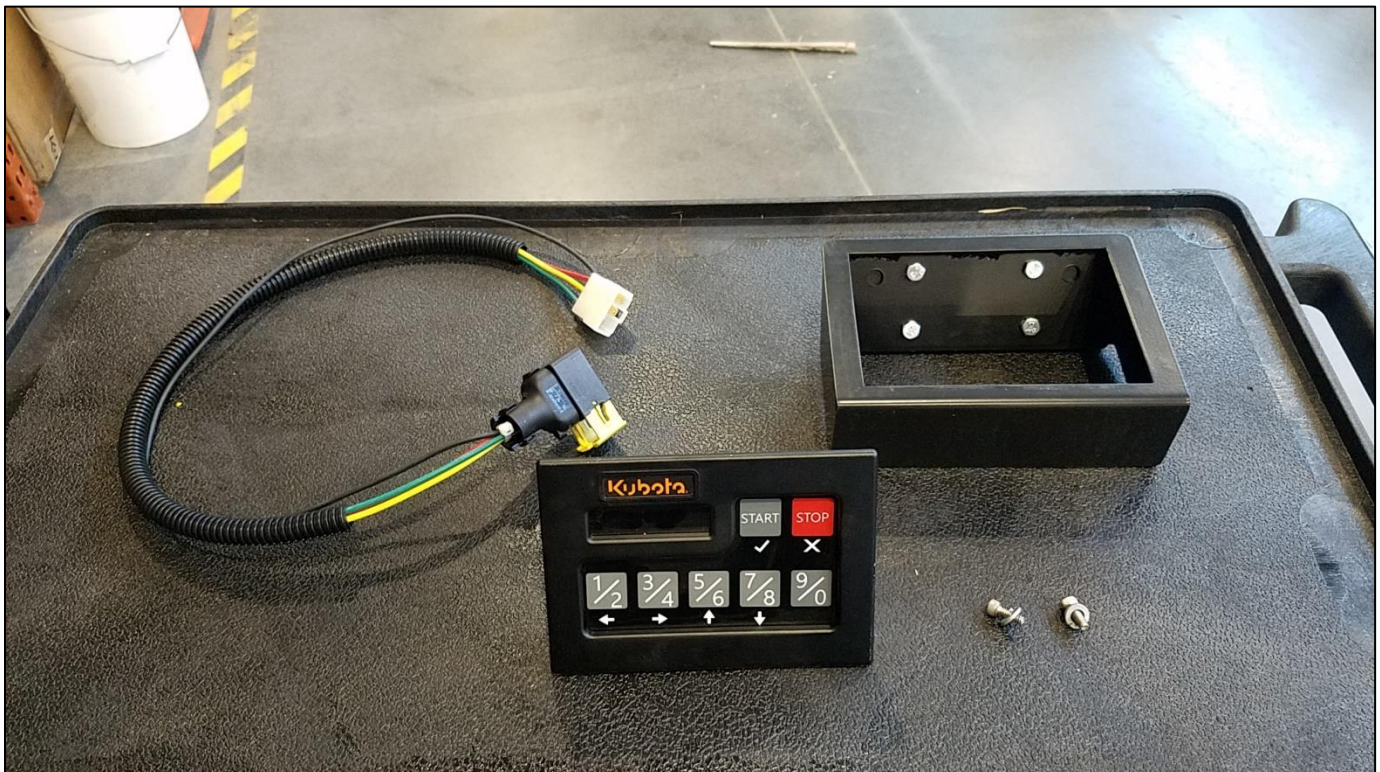

NOTE:

- Check the contents as shown in the parts list

■ PARTS LIST

Ref. No.	Part No.	Part Name	Q'TY	REMARKS
1	77700-10657	RTV (Gas) Keyless Start Keypad Kit	1	
2	77700-10658	RTV (Diesel) Keyless Start Keypad Kit	1	
3		RTV RTV Bracket	1	NSS
4		RTV Gas Wire Harness	1	NSS (included with 77700-10657)
5		RTV Diesel Wire Harness	1	NSS (included with 77700-10658)
6		M6 bolts, nuts	4	NSS
7		"L" Bracket	2	NSS
8		Allen head bolts, lock washers	2	NSS

NSS: Not sold separately

IMPORTANT: Keep all decals clean and legible. Replace all missing, illegible, or damaged decals.

■ MACHINE PREPARATION

WARNING

To avoid personal injury or death:

- Park the machine on a firm and level surface.
- Apply the parking brake.
- Stop the engine and remove the key from the machine.
- Disconnect negative (-) terminal on battery before performing work.
- Do not short circuit the battery, starter motor or electrical circuits.

NOTE:

- **All assembly procedures listed within this manual are generally representative of the machine model for which the manual is written.** Your machine may be configured differently, but the outline for the procedure should still be followed. For further support for any issues not covered within the pages of this manual, please contact your local Kubota representative.

■ ASSEMBLY PROCEDURE FOR RTV-X1100C ESTIMATED INSTALL: 45 MIN

1. Remove lower section of plastic dash by removing (10) Allen head bolts using 5mm Allen wrench. (Figure 1)



Figure 1.

2. Connect RTV (Diesel) Wire harness to connector in back of keypad. Ensure that the connector is firmly connected and locked. (Figure 2)



Figure 2.

3. Feed wire harness through RTV Bracket opening and lay keypad into RTV Bracket.
4. Hold RTV Bracket and keypad to middle of plastic dash panel and mark corners with permanent marker. When holding on surface ensure that keypad connector does not contact dash panel (Figure 3-5)



Figure 3.



Figure 6.



Figure 4.

8. Re-insert keypad into RTV Bracket and secure with "L" brackets.(Figure 7)

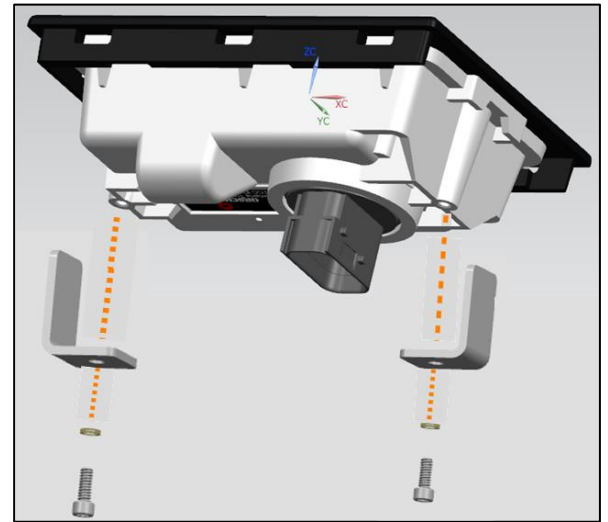

Figure 7.



Figure 5.

9. Disconnect machine key switch harness. Remove key switch if desired.
10. Connect Keyless Start wire harness to machine key switch harness.
11. Locate frame bolt above brake pedal. (Figure 8) Remove RH bolt and connect black wire from wire harness using ring terminal. Re-tighten bolt.

5. Remove keypad from RTV bracket. Hold on corner marks made in step 5 and mark holes with marker. (Figure 5)
6. Use 1/4" or 6.5mm drill bit to drill 4 marked holes in dash panel.
7. Align RTV Bracket on front of plastic panel with drilled holes in dash and rear plate on backside of dash. Insert M6 bolts and tighten nuts. (Figure 6)



Figure 8.

12. Re-install lower dash panel.
13. Secure ground wire using zip ties (not provided). Ensure that it does not hang down and interfere with brake or throttle pedal operation. Trim zip ties.

14. Re-attach battery ground terminal.
15. Press "Start" button on keypad to ensure keypad powers on. If keypad doesn't power on check all connections first.

■ **ASSEMBLY PROCEDURE FOR RTV-XG850, RTV-X900, RTV-X1120, RTV-X1140**
ESTIMATED INSTALL: 30 MIN

1. Connect RTV Wire harness (Gas harness for RTV-XG850, Diesel harness for diesel models) to connector in back of keypad. Ensure that the connector is firmly connected and locked. (Figure 1)



Figure 1.

2. Feed wire harness through RTV Bracket opening and lay keypad into RTV Bracket.
3. Hold RTV Bracket and keypad up to middle lower dash area to find proper location. (Figure 2) Ensure that RTV Bracket is low enough that keypad connector does not interfere with dash. Ensure that keypad does not cover 'Important' Label



Figure 2.

4. Mark corners of RTV Bracket with permanent marker and remove keypad from RTV Bracket.
5. Hold RTV Bracket into position on dash and mark 4 holes with permanent marker.
6. Use 1/4" or 6.5mm drill bit to drill 4 marked holes in dash panel.
7. Align RTV Bracket on front of plastic panel with drilled holes in dash and rear plate on backside of dash. Insert M6 bolts and tighten nuts.

8. Re-insert keypad into RTV Bracket. Secure keypad into RTV Bracket using (2) "L" RTV Brackets and Allen headed bolts with lock washers. Allen headed bolts thread directly into keypad housing. (Figure 3)

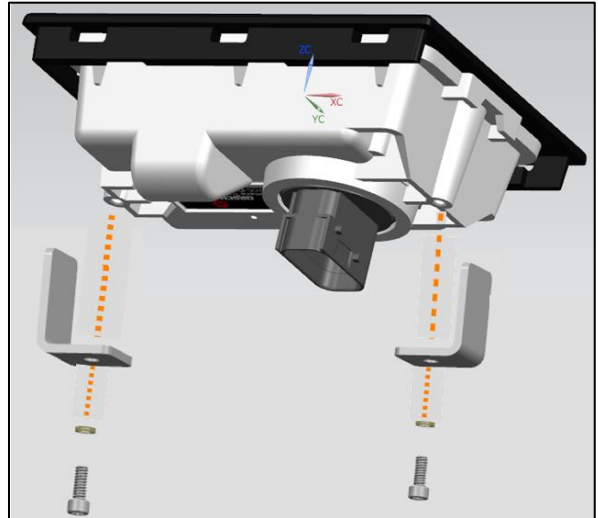

Figure 3.

9. Disconnect machine key switch harness. Remove key switch if desired.
10. Connect Keyless Start wire harness to machine key switch harness.
11. Locate grounding bolt under hood. (Figure 4) Remove front bolt and connect black wire from wire harness using ring terminal. Re-tighten bolt.



Figure 4.

12. Secure ground wire using zip ties. Ensure that it does not hang down and interfere with brake or throttle pedal operation.
13. Re-attach battery ground terminal.
14. Press "Start" button on keypad to ensure keypad powers on. If keypad doesn't power on check all connections first.