



For Earth, For Life  
Kubota

R

KUBOTA WHEEL LOADER  
R540/R640

Kubota's next-generation R540 and R640 wheel loaders bring you comfort, easy operation, and all the power you need.



Kubota®

KUBOTA TRACTOR CORPORATION

1000 Kubota Drive, Grapevine, TX 76051 Tel 888-4 KUBOTA

Visit our web site at: [www.kubotausa.com](http://www.kubotausa.com)

©2021 Kubota Corporation



Kubota  
Genuine Parts  
for maximum  
performance,  
durability and  
safety



# Comfort, easy operation, and all the power you need.

Kubota's next-generation R540 and R640 wheel loaders are built to get the job done quickly, easily, and efficiently. They're built for comfort, with a new, high-visibility cabin. They're also built for simple and productive operation, even by operators with novice experience. And they're built for performance, with enhanced productivity features and power to spare.



KUBOTA WHEEL LOADER

# R540/R640

# OPERATOR COMFORT / EASE OF USE

Redesigned inside and out, both the R540 and R640 wheel loaders boast a fully enclosed glass cabin for improved visibility, as well as a more ergonomic control layout.



## A Full-suspension seat

A full-size, full-suspension adjustable seat enhances operator comfort. The padded seat can be moved forward or back for optimum comfort.

## B Adjustable right wrist rest

This feature reduces fatigue by reducing arm movement and allowing you to more easily operate the hand lever.

## C Tilt steering

With the flick of a lever, the steering wheel can be tilted up or down to the most comfortable and efficient position for operators of all sizes.

## Full opening Right window

The window on the right side of the cabin opens fully to improve ventilation as well as communication with workers outside.

## New interior design

The spacious cabin's ergonomic layout is designed to keep you working comfortably from start to finish.

## Air conditioning

A powerful heating/cooling system and eleven vents provide optimum comfort on the coldest winter and hottest summer days.

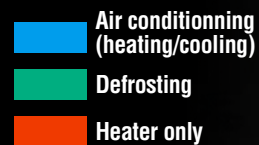

## High-visibility cabin

Fully enclosed in glass, the high-visibility cabin offers the operator a panoramic perspective of the environment outside, with the pallet fork tips clearly visible from the driver's seat. The full glass door, and wide opening window provide excellent visibility to the left and right, while the rear window offers an unobstructed view when traveling in reverse.

## ROPS/FOPS cab and canopy

Manufactured and attached at the Kubota factory, both the Roll-Over Protective Structure (ROPS) and Falling Object Protective Structure (FOPS) meet the applicable ISO, SAE standards and OSHA regulations.

# PERFORMANCE

Long reach and excellent lifting power ensure superior performance for a wide range of loader tasks.



## Working range

A long reach and high clearance make all types of material handling jobs easy. The high clearance lets you load trucks with ease, while the superior reach makes pallet fork operations faster and more efficient.

## Arm tilt / Parallel movement

Transporting a fully loaded pallet with the pallet fork, Kubota's arm tilt/parallel movement structure keeps the load upright and steady, even while raising or lowering the lift arm.

## Powerful lifting capacity

An improved lifting force provides smooth operation for both R540 and R640, while lifting and handling material in a variety of applications.

## Multi-function operating lever

All major loader functions are on a single lever that is easy to operate with just one hand, both on the R540 and R640. The 2-step speed control switch lets you quickly change speeds, allowing you to operate at optimum efficiency for the task at hand.

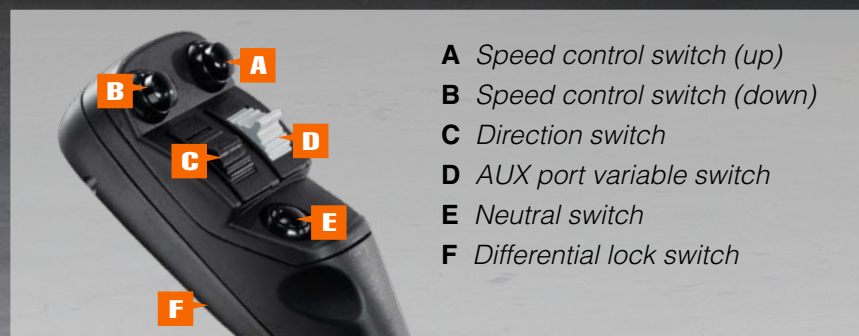

## Kubota original DI engine with CRS and DPF muffler

The new Kubota's V2607 direct-injection engine is equipped with CRS and with a new and improved DPF which reduces maintenance by increasing the service intervals for both the regeneration filter and ash cleaner.

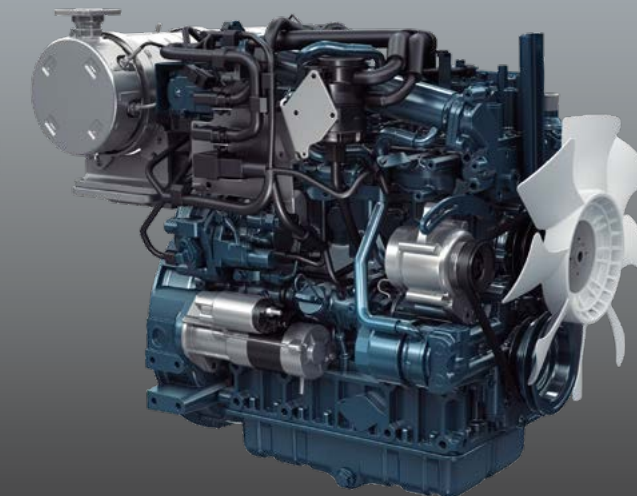

## GROSS ENGINE OUTPUT

**R540: 50.9 HP**

**R640: 64.3 HP**

## Differential lock (100% On demand, front & rear)

Should the wheels start to slip, simply press the differential lock switch to immediately engage both front and rear wheels. The result is positive slip-free traction.

# SERVICE

Simple maintenance ensures that your R540 and R640 loaders are productive.

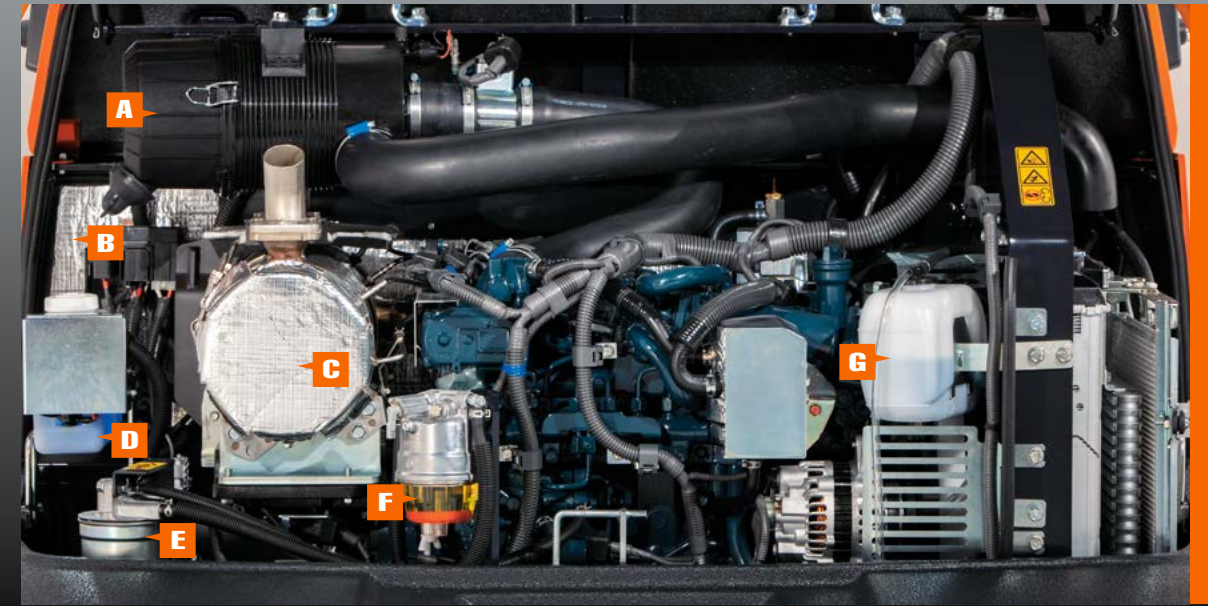

## Easy maintenance

The engine bonnet at the rear opens wide, providing quick and easy access to the machine's main service areas. Items that require routine maintenance and service are within easy reach for fast and simple servicing. Quick-open panels on the right and left sides provide speedy access to the fuel refill (right side) and battery (left side). Other areas of the R540 and R640 are also easy to service and maintain.

- A** DUAL ELEMENT AIR CLEANER
- B** BATTERY
- C** DIESEL PARTICULATE FILTER (DPF) MUFFLER
- D** WASHER TANK
- E** FUEL FILTER
- F** WATER SEPARATOR
- G** RESERVE TANK

## New LED work lights

Bright LED work lights provide plenty of illumination for nighttime tasks.



## Easy transportation

With an overall height of 8'2" or less, the R540 and R640 fit easily under road bridges for fast and efficient transportation between job sites. Six tie-down points allow simple yet secure attachment to a truck bed for safety during transportation.

## Digital diagnostic indicators

A bright easy-to-read digital diagnostic indicator keeps you fully informed of critical loader and engine conditions.

**Error display**

Hydraulic oil temperature has reached a specified level	Meter ECU communication error	Parking brake error	Fuel sensor system error

## Standard equipment

### Safety

- 6 Tie down points
- Lift arm support
- Towing pin

### Working equipment

- 2 Head lights (Headlights and Signal Lights)
- Rear combination lights (Turn signal, Tail light, Brake light, Backup light)

### Operator's space

- Canopy (ROPS / FOPS Level1)
- Weight-adjustable suspension seat (PVC seat) with left arm rest and back rest
- Retractable seatbelt
- Adjustable right wrist rest
- Digital panel with diagnostic function
- Side mirrors
- 12V power outlet
- Tool storage space - Canopy models
- Tilt steering
- Cup holder

### Engine/Fuel system

- KUBOTA original engine
- Double-element air cleaner

- Fuel level indication buzzer
- Fuel / water separator
- Separate fuel filter

### Travel system

- Differential lock (100% on demand, front and rear)
- Wet type disc brake
- Negative brake (parking brake)
- Wide tire (R540: 365/70R18 / R640: 405/70R18)

### Hydraulic system

- Hydrostatic transmission
- Multi-function operating lever with AUX proportional control
- Hydraulic lock switch
- Inching and brake pedal (left)
- Hydraulic quick coupler switch
- Loader float switch

### Others

- Maintenance free battery
- Grease gun holder
- Radio ready

## Optional equipment

- Cab with air conditioner
- Beacon light
- Inching and brake pedal (right)
- Kubota Shockless Ride (KSR)
- Tool box for cab models
- Rear working LED lights
- Various buckets and other attachment
- Block heater
- 3" retractable seat belt
- Hydraulic Euro-type coupler
- Hydraulic SSL-type coupler
- Mechanical SSL-type coupler

### Stay connected with KubotaNOW

KubotaNOW telematics gives you the right information, when and where you need it. To access KubotaNOW telematics information, download the myKubota app and stay connected to your Kubota machine. Get information like hours, fuel level, location, temperatures, error codes, and more.



## Working range

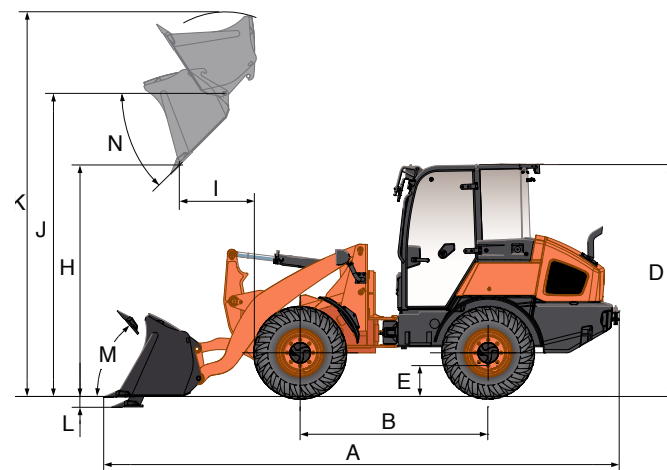
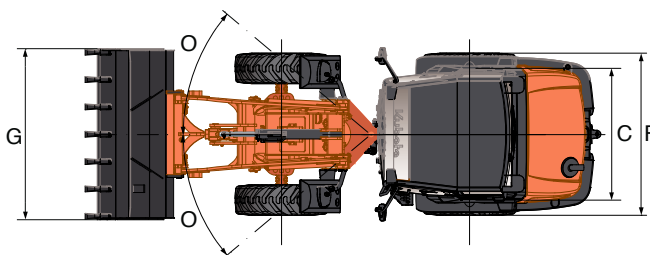

Model		R540	R640
A	Overall length	ft.in. (mm)	17' 9" (5400) / 18' 0" (5480)
B	Wheelbase	ft.in. (mm)	6' 7" (2000)
C	Tread	ft.in. (mm)	4' 5" (1355) / 4' 7" (1400)
D	Overall height (canopy / cabin)	ft.in. (mm)	8' 1" (2455) / 8' 1" (2475) / 8' 2" (2480) / 8' 2" (2500)
E	Ground clearance	in. (mm)	12.6" (320) / 13" (340)
F	Overall width (outside of tires)	ft.in. (mm)	5' 8" (1720) / 5' 11" (1805)
G	Overall width (bucket)	ft.in. (mm)	6' 2" (1867) / 6' 4" (1918)
H	Dumping clearance	ft.in. (mm)	8' 0" (2430) / 7' 10" (2385)
I	Dumping reach	ft.in. (mm)	2' 7" (780) / 2' 8" (825)
J	Max. hinge pin height	ft.in. (mm)	10' 7" (3230) / 10' 8" (3255)
K	Max. lifting height	ft.in. (mm)	13' 5" (4080) / 13' 8" (4175)
L	Digging depth	in. (mm)	6.1" (155) / 5.1" (130)
M	Tilt back angle (at traveling position)	Deg.	52
N	Dumping angle	Deg.	44
O	Articulation angle	Deg.	40

## Specifications

Model		R540	R640
Type of ROPS / FOPS		CANOPY / CAB	
		V2607-CR-E5-WL	V2607-CR-TE5-WL
Engine		Tier4 Final	
Model			
Emission certification			
Output (SAE J1995 gross)		HP (kW) @ rpm	50.9 (38.0) @ 2400 / 64.3 (48.0) @ 2400
Output (SAE J1349 net)		HP (kW) @ rpm	47.9 (35.7) @ 2400 / 61.1 (45.6) @ 2400
Displacement		cu.in. (cc)	160 (2615)
Transmission		Hydrostatic transmission	
Type			
Dimensions			
Overall length		ft.in. (mm)	17' 9" (5400) / 18' 0" (5480)
Overall height		ft.in. (mm)	8' 1" (2455) / 8' 2" (2475) / 8' 2" (2480) / 8' 2" (2500)
Overall width (w/o bucket)		ft.in. (mm)	5' 8" (1720) / 5' 11" (1805)
Ground clearance		in. (mm)	12.6" (320) / 13" (340)
Auxiliary circuit			
Auxiliary hydraulic flow		gpm (ℓ/min.)	14.2 (54) / 17.8 (67.2)
Auxiliary hydraulic pressure		psi (Mpa)	2683 (18.5) / 2973 (20.5)
Tire size		365/70R18 / 405/70R18	
Travel speed		mph (km/h)	0 - 12.4 (0 - 20.0)
Max. traction force		lbs. (kN)	6541 (29.1) / 8588 (38.2)
Front/Rear axle traction lock		Diff-lock (both axles)	
Articulation angle		40 (each direction)	
Angle of rear frame oscillation		±8	
Loader clearance circle		ft.in. (mm)	13' 8" (4175) / 13' 10" (4221)
Turning radius track circle		ft.in. (mm)	11' 11" (3620) / 12' 0" (3664)
Brakes		Enclosed wet disc	
Service		Spring applied hydraulic released wet disc	
Parking			
Lifting specifications			
Tipping load (straight)		with bucket lbs. (kg)	6437 (2920) / 6768 (3070) / 7452 (3380) / 7760 (3520)
		with pallet forks lbs. (kg)	4960 (2250) / 5202 (2360) / 5820 (2640) / 6063 (2750)
Tipping load (full turn)		with bucket lbs. (kg)	5644 (2560) / 5930 (2690) / 6526 (2960) / 6812 (3090)
		with pallet forks lbs. (kg)	4365 (1980) / 4586 (2080) / 5115 (2320) / 5313 (2410)
Operating capacity		with bucket (50%) lbs. (kg)	2822 (1280) / 2965 (1345) / 3263 (1480) / 3406 (1545)
		with pallet forks (60%) lbs. (kg)	2624 (1190) / 2756 (1250) / 3064 (1390) / 3197 (1450)
Operational specifications			
Standard bucket capacity		yd³	0.85 / 0.94
Breakout force		lbs. (kN)	7761 (34.5) / 8526 (37.9)
Lifting capacity at ground level		lbs. (kN)	6767 (30.1) / 8161 (36.3)
Loader raise / lower time		sec.	6.5 / 4.5 / 5.8 / 3.9
Fuel tank		gal. (ℓ)	18.5 (70)
Hydraulic system		gal. (ℓ)	14.5 (55)
Hydraulic reservoir		gal. (ℓ)	10.3 (39)
Operating weight (Including operator weight @ 165lbs.)		lbs. (kg)	9888 (4485) / 10285 (4665) / 11177 (5070) / 11563 (5245)

## Pallet fork specifications

Model		R540	R640
Fork length		48" (1220)	
in. (mm)			
A1	Overall length	ft.in. (mm)	19' 10" (6041) / 19' 9" (6026)
B1	Height of forks at Max. reach	ft.in. (mm)	4' 7" (1387) / 4' 8" (1412)
C1	Height of forks at Max. height	ft.in. (mm)	10' 0" (3053) / 10' 2" (3078)
D1	Reach at ground level	ft.in. (mm)	3' 1" (941) / 2' 11" (896)
E1	Max. reach	ft.in. (mm)	4' 8" (1410) / 4' 7" (1387)
F1	Reach at Max. height	ft.in. (mm)	2' 2" (647) / 2' 1" (622)

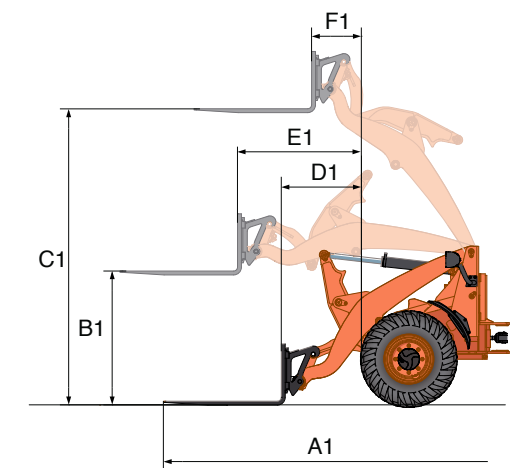

Note: The above dimensions are based on the machine with wide tires, SSL type quick coupler, standard bucket/pallet fork and ROPS/FOPS canopy and cabin.

Kubota Tractor Corporation reserves the right to change the stated specifications without notice. This brochure is for descriptive purposes only and reasonable efforts were used to set forth the contained information; some items shown may be optional and some products shown may not be available at all dealerships. Kubota disclaims all representations and warranties, express or implied, or any liability from the use of this brochure. For complete warranty, safety and product information, consult your local Kubota dealer and the operator's manual. Power (HP/KW) and other specifications are based on various standards or recommended practices. For your safety, Kubota strongly recommends the use of a Rollover Protective Structure (ROPS) and seat belt in almost all applications. This brochure is intended for the United States and US territories only. For information regarding Kubota products or services outside these areas, see Kubota Corporation's global web site. Kubota does not provide parts, warranty or service for any Product which is re-sold or retailed in any country other than the country for which the Product(s) were designed or manufactured.

★ All images shown are for brochure purposes only.  
When operating the wheel loader, wear clothing and equipment in accordance to local legal and safety regulations.