



For Earth, For Life
Kubota

KX

KUBOTA COMPACT EXCAVATOR KX040-4

The superior compact excavator that combines exceptional strength and versatility with performance and user-friendly operation.



Superior 4-ton muscle and clean engine performance make the KX040-4 the ideal choice for the urban jungle.

CLEAN AND POWERFUL EXCAVATOR



WERFUL

Common Rail System and Diesel Particulate Filter (DPF) muffler

The Common Rail System (CRS) electronically controls the fuel injection timing and amount in stages rather than all at once for optimal combustion. The results are greater efficiency, better fuel economy and less engine noise. Its combination with the Exhaust Gas Recirculation (EGR) and Diesel Particulate Filter (DPF) Muffler reduces harmful emissions to make the KX040-4 Tier IV-compliant.

Automatic regeneration system

Kubota's original automatic regeneration system automatically burns accumulated particulate matter (soot) in the DPF muffler to keep the muffler clean for longer operation. For safety reasons, automatic regeneration can be turned off with the inhibit switch when the excavator is operating in areas that are prone to fires.



Introducing ECO PLUS[®]

Kubota's original ECO PLUS prioritizes fuel economy, and supports the environment.

For tough digging applications, use Standard Mode and experience a 3% productivity improvement over the prior model and use less fuel, up to 12% less.

Activate Eco Mode with the flick of a switch for up to 9% fuel savings over Standard Mode.



Eco Mode Switch

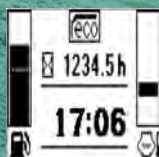

Eco Mode Indicator

STANDARD MODE

- Improved Productivity
- Lower Fuel Consumption

Compared to Prior Model

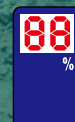

Save
12%*

ECO MODE

- Focus on Lower Fuel Consumption

**Compared to Standard Mode*

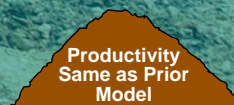

Save
9%*

DELUXE INTERIOR

The KX040-4 raises the standard in 4-ton excavator comfort with a spacious cab that rivals 5-ton excavators. The luxurious cab features a wider entrance, greater legroom and a deluxe seat. Operability is greatly enhanced with more easy-to-use features than ever before.

New spacious cab

Designed for greater comfort, the new large cab with a fully flat floor provides more legroom to minimise fatigue.

Easy-open front side window

Unlike many excavator windows, the front glass window of the KX040-4 opens with ease. Just flip the latches on the window sides and slide it up. A gas-assist mechanism makes this action almost effortless.

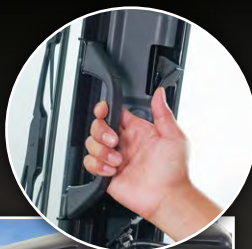

Wider entrance

The KX040-4's larger cab provides a much wider door and more ample foot space, to make getting on and off the excavator a breeze.





A. Deluxe suspension seat

Designed and engineered to fit better and to keep you working longer comfortably, Kubota's high-back suspension seat reduces strain and minimizes operator fatigue. It reclines to accommodate your individual posture, and offers weight compensation, firm and adjustable wrist support and retractable seat belts.

B. 2-speed travel switch

By placing the 2-speed travel switch on the dozer lever, dozing operations can be done faster and easier.



C. Cup holder

With the convenience of a bigger cup holder, you can quench your thirst and work longer without leaving the cab. Or store your cell phone. The charging port is located conveniently close by.

D. Wrist rest

A thoughtfully designed wrist rest enhances operation and reduces operator fatigue.

E. Air conditioning

The overall air circulation in the cab has been improved, thanks to a stronger cooling/heating unit and the positioning of six vents around the operator to offer better all-round comfort.



Fully flat floor

For added comfort, the cabin floor is completely flat for greater legroom and a more spacious feel.



SUPERIOR PERFORMANCE



Proportional flow control of auxiliary circuit (AUX1/2) and maximum oil flow setting

The KX040-4 is available with a standard AUX1 and optional AUX2 auxiliary circuits. The convenient thumb-operated switch on the lever allows easy proportional flow control of the auxiliary circuit, while a forefinger-operated on/off switch enables simple operation of special applications that require a constant oil flow. The maximum oil flow setting is conveniently adjustable from the digital panel. Up to five flow rates corresponding to specific attachments can be programmed in the memory on the digital panel for easy retrieval for the next job.



Strong bucket breakout

Even when heavily loaded, the KX040-4 won't slow down, thanks to its powerful breakout force. With the pin-on or quick coupler bucket, the bucket breakout force is more than enough for even the toughest excavating jobs.

Thumb bracket and relief valves

The hydraulic thumb makes short work of a variety of loading and material handling jobs. The factory installed mount brackets and hydraulics significantly reduce the time needed to mount accessories.

AUX1 diverter valve

With the AUX1 diverter valve, the AUX oil supply can be changed without having to remove the thumb pipeline when the operator wants to use a hydraulic attachment.

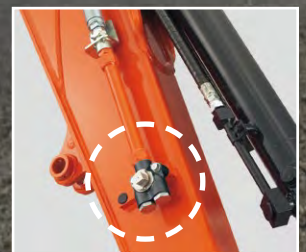

Third line hydraulic return

When working with one-way hydraulic attachments, such as a breaker or brush cutter, the standard third-line hydraulic return system allows oil to flow directly back to the tank without running through the control valves. This contributes to less oil contamination, reduced back pressure, and greater oil flow efficiency.





Hydraulic 6-in-1 Blade Models

Kubota's hydraulic 6-in-1 Blade can be angled right and left, and now, tilted as well. This blade enables six different positions: neutral, float-up, left-end-up, right-end-up, left-end-forward and right-end-forward. This feature makes leveling and backfilling work incredibly easy, even on inclines and uneven terrain, making you more productive and more efficient.

Tilt blade control

The 6-in-1 blade is a true productivity enhancer, and operation is now even more rewarding. Blade up, down, and float functions are the same as the previous model. Operate the rocker switch on top of the blade control to tilt the blade 10° up or down, and simply twist the control handle to angle the blade 25° left or right. Command all six functions simultaneously for more convenient control of landscaping, shaping, and backfilling jobs.

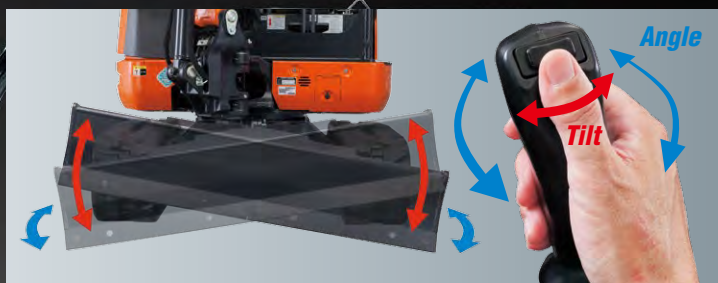

Superior width and tilt angle

This 5' 10.9"-wide blade stretches across the entire machine width, even when tilted. It can be tilted a generous 10 degrees right or left, allowing the operator to dig ditches easily when tilted on a flat surface.

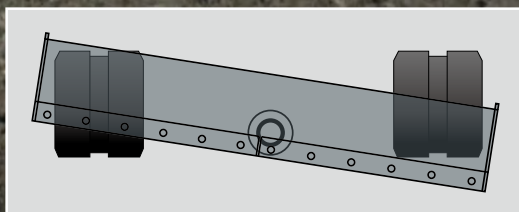

Bolt-On cutting Edge (BOE)

The cutting edge protects the angle blade during heavy-duty dozing operations. The reversible cutting edge is divided into two sections to easily invert the edge for continued use.

Tie-down/lift points

The dozer blade's thick side plates improve the tie-down point's durability. Use them also as lifting points, along with the lifting point on top of the boom, for convenient 3-point crane lifting of the KX040-4.



Angle Blade Models

Save time and work more efficiently. With a simple movement of the blade lever, the hydraulic angle blade can be angled to the right or left to push soil to the side as the machine moves forward, eliminating the need for repetitive repositioning at right angles when backfilling trenches.

Angle Blade control

Simply operate the rocker switch on the top of the blade lever to angle the blade up to 25° left or right. Work more efficiently and save time pushing soil to the side as the machine moves forward. After backfilling, just travel backward along the covered trench with the dozer in the float position for a beautiful finish!

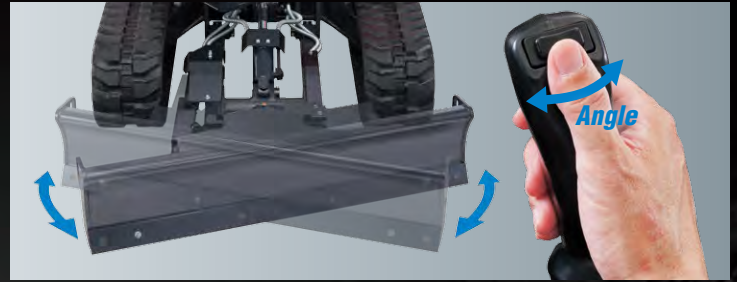

What makes our Angle Blade excavator so productive? Check it out.

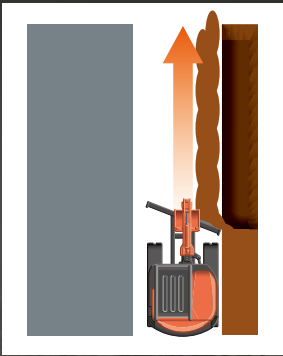

With Angle Blade

Moving only in a forward direction one time, which is equivalent to a trencher backfilling its one side, the KX040-4 Angle Blade excavator backfills smoothly and efficiently.

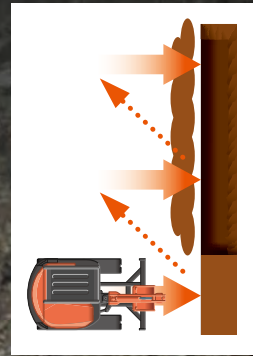

Without Angle Blade

Without the angle blade feature, time-consuming, repetitive repositioning at right angles to the trench is required.

Float position

The float function is a standard feature on the KX040-4. Ground finishing work can be completed quickly and simply without the need to adjust the dozer height. After backfilling, simply travel backwards along the covered ditch with the dozer in the float position.



Fully locked hydraulic system

An Engine Start Lockout System prevents the engine from starting when the safety levers are lowered. A Safety Lever Lockout System helps prevent unexpected excavator and attachment movement when entering or exiting the machine. An Auto House Parking Brake automatically locks the house in the position it was in when the engine was shut off, eliminating the need for a swing lock pin. It also makes the excavator more compact during transport and more secure when parked on an incline.



TPSS

The Two-Pattern Selection System positioned under the seat allows the operator to shift control styles conveniently while seated. A simple turn of a switch is all it takes to select between the ISO pattern and the SAE backhoe pattern.

The KX040-4 has the power and versatility to take on almost any task even in the toughest conditions. Combined with improved digging and lifting power, and smoother travel performance, it can get the job done right!

ROPS/OPG (TOP Guard, Level I) canopy and cabin

The OSHA-certified ROPS/OPG (Top Guard, Level I) canopy and cabin provide protection in the event of accidental rollovers and falling objects.



Auto idling system

Save fuel with Kubota's Auto Idle. When the control levers are in neutral for more than 4 seconds, the engine RPM automatically idles. Move any control lever and the engine RPM immediately returns. This innovative feature reduces noise and exhaust emissions while reducing operating costs.

Auto down shift

The auto down shift system enables automatic travel shift from high to low depending on traction effort and terrain. This gives smoother simultaneous operations when dozing and turning.



One-sided engine maintenance

Kubota has made routine maintenance extremely simple by consolidating primary engine components onto one side for easier access. Engine and other vital components can be inspected quickly and easily.

DPF muffler

Fuel filter

Alternator

Fuel/water separator

Clean fuel is of paramount importance for our Tier 4 engines, so we have made it easy to check and drain accumulated water. The fuel/water separator has a clear bowl for easy visibility of accumulated water. Simply open the drain spout to remove accumulated water without having to open the filter assembly.

Starter motor



Engine oil gauge



Engine oil filter



MAINTENANCE

Although your Kubota excavator is state-of-the-art, its maintenance doesn't get much easier. Thanks to the full-opening rear and right side hoods, engine, control valves and various components are accessible for easy inspection and repair.

LASTING DURABILITY

Kubota has a reputation for quality products that are consistently reliable, offering operators an unrivaled level of confidence and peace of mind. Every component of the KX040-4 has been thoroughly engineered for a longer lifecycle, providing the power you demand and the durability you deserve.

Centralized swivel bearing lubrication

Grease ports for the swivel bearing, gear teeth, and swing cylinder pin are conveniently grouped on the front of the house.

Front pin bushings

To maximize durability, we've introduced bushings on all of the pivot points on the front attachment and connecting points on the swing bracket.



Protected cylinder hoses

The bucket cylinder hoses are located inside the arm. And the boom cylinder hoses are routed under the boom bottom.

Two-piece hose design

The two-piece hose connections for the dozer cylinder hoses simplify hose replacement and reduce downtime.



Dual element air filter

Excavators often operate in dusty conditions. To maintain outstanding engine durability, dual element air filters help ensure that only clean air enters the engine.



NEW DIGITAL PANEL

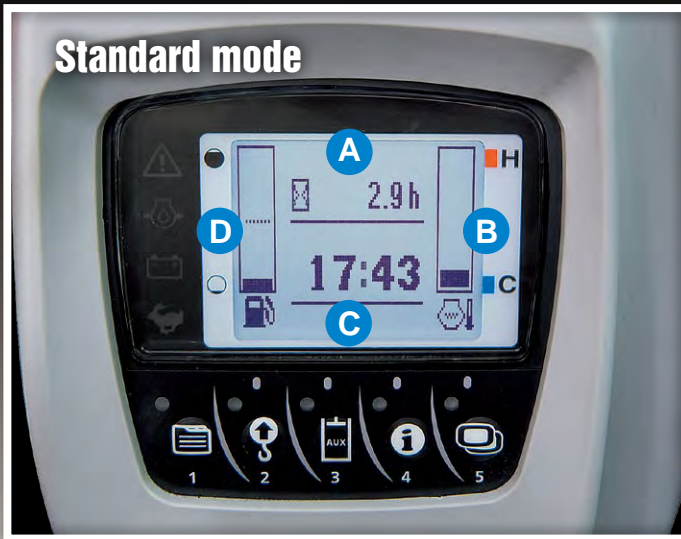

- A. Hour meter**
- B. Coolant temperature**
- C. Clock**
- D. Fuel level**
- E. Engine RPM**



Following the excellence of Kubota's Intelligent Control System, the new digital panel puts convenience at the operator's fingertips. Featuring easier button operation, the user-friendly digital panel is positioned to the front right corner of the operator. This operator-facing wider display greatly improves visibility. With easier access, simpler settings, easy-to-read indicators and alerts, you'll always be aware of the excavator's functioning status.

Operation history record

Operation history is automatically recorded on the KX040-4. You can trace back up to 90 days of the machine's usage dates by simply checking the built-in calendar.

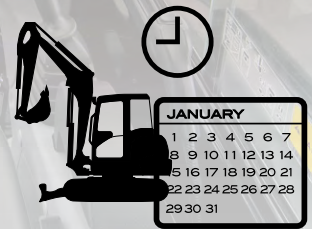

Service mode



Warning mode



Operation history record



Max. oil flow setting (AUX1 and optional AUX2)

Automatic regeneration mode

The automatic regeneration system automatically burns particulate matter (soot) that accumulates in the diesel particulate filter (DPF) muffler. The soot is burned when the engine is operating at sufficient engine speed for regeneration. If the engine speed is lower than the required level for regeneration, the indicator requests an increase in the engine speed to keep the accumulation level low and the DPF clean. A service call or DPF filter replacement is required when the accumulated soot reaches a level that reduces the engine speed.



KX040-4 OPTIONS

STANDARD EQUIPMENT

Safety system

- Engine start safety system
- Travel motor with disc brake
- Swivel motor with disc brake
- All hydraulic control

Working equipment

- Auxiliary hydraulic circuit 1
- 2 working lights on cab and 1 light on the boom
- Dozer blade with float function
- Thumb bracket and relief valve

Operator's space

- ROPS/OPG (TOP Guard, Level I) canopy
- Weight-adjustable full suspension seat
- Retractable seat belt
- Hydraulic pilot control levers with wrist rests
- Travel levers with foot pedals
- Two pattern selection system
- Digital panel
- 12V power source
- Cup holder
- Horn

Engine/Fuel system

- Double element air filter
- Auto idling system
- Water separator with drain cock

Undercarriage

- 1'1.8" (350 mm) rubber track
- 1 × upper track roller
- 4 double-flange track rollers on each side
- 2-speed travel switch on dozer lever
- 2-speed travel with auto-shift

Hydraulic system

- 1-pump load sensing system
- Pressure accumulator
- Hydraulic pressure checking ports
- Straight travel circuit
- Third line hydraulic return
- Auxiliary switch (AUX1) on right control lever
- Adjustable maximum oil flow on auxiliary hydraulic circuits 1

Others

- Tool box
- Grease gun holder

OPTIONAL EQUIPMENT

- 6 in 1 blade with float function and BOE
- Angle blade with float function and BOE
- Cab with A/C
- Canopy lights
- Beacon lights
- 1'1.8" (350 mm) steel track
- Additional auxiliary hydraulic circuit 2 (adjustable max. oil flow control)
- Travel alarm
- Mirror kit
- Cab radio
- Hydraulic breaker
- Hydraulic thumb
- Pin-on and quick attach buckets

WORKING RANGE

Model			KX040-4
A	Max. digging height	ft. in. (mm)	17'6" (5335)
B	Max. dumping height	ft. in. (mm)	12'9.5" (3900)
C	Max. digging depth	ft. in. (mm)	11'2.7" (3420)
D	Max. vertical digging depth	ft. in. (mm)	7'4.8" (2255)
E	Max. digging radius, at ground level	ft. in. (mm)	17'9" (5410)
F	Max. digging radius	ft. in. (mm)	18'2.1" (5540)
G	Min. turning radius	W/o swing ft. in. (mm)	7'1.8" (2180)
		W swing ft. in. (mm)	5'11.1" (1805)
H	Min. tail turning radius	ft. in. (mm)	4'3.2" (1300)

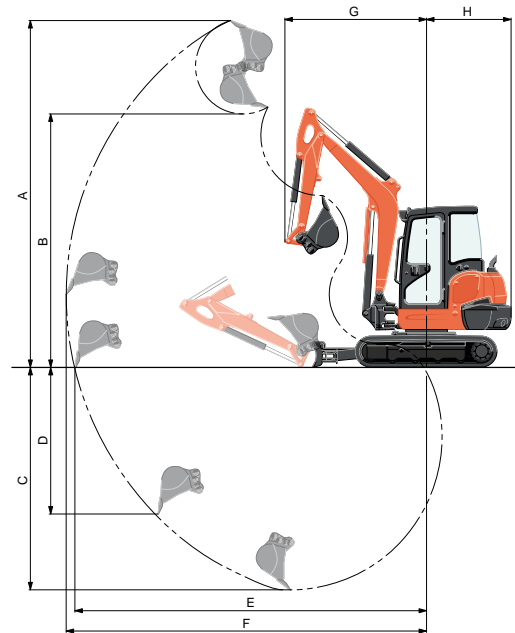

LIFTING CAPACITY

Cab rubber

LIFT POINT HEIGHT (ft)	LIFTING CAPACITY OVER-FRONT BLADE DOWN unit=1000 lbs			LIFTING CAPACITY OVER-SIDE unit=1000 lbs			
	LIFT POINT RADIUS (ft)			LIFT POINT RADIUS (ft)			
	8	12	14	8	12	14	
6	2.72	1.91	1.75	2.72	1.60	1.27	
4	3.54	2.13	1.86	2.76	1.55	1.25	
2	4.08	2.32	1.96	2.65	1.51	1.22	
GL	0	4.25	2.43	2.01	2.60	1.48	1.21

Machine with cab and rubber crawler, without bucket, with standard blade

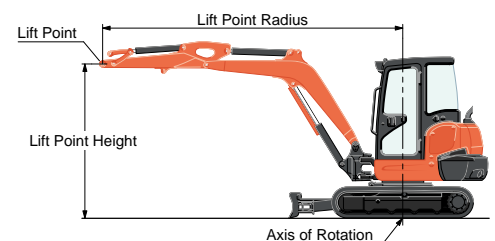

SPECIFICATIONS

Model		KX040-4	KX040-4 Angle Blade	KX040-4 6-in-1 Blade		
Type of ROPS / OPG (TOP Guard, Level I)*		Canopy / Cab				
Type of tracks		Rubber / Steel				
Engine	Model	Kubota D1803-CR-TE4				
	Output (SAE J1995 gross)	HP (kW) / rpm	40.4 (30.1) / 2200			
	Output (SAE J1349 net)	HP (kW) / rpm	38.9 (29.0) / 2200			
	Displacement	cu. in. (cc)	111.4 (1826)			
Dimensions	Overall length	ft. in. (mm)	16'8.2" (5085)			
	Overall height	Canopy / Cab ft. in. (mm)	8'1.8" (2485) / 8'1.8" (2485)			
	Overall width	ft. in. (mm)	5'6.9" (1700)	5'10.9" (1800)		
	Min. ground clearance	in. (mm)	12.99" (330)			
Hydraulic system	Pump capacity	GPM (ℓ/min)	24.4 (92.4)			
	Auxiliary hydraulic flow	AUX1 / AUX2 GPM (ℓ/min)	17.2 (65) / 9.8 (37)			
	Max. breakout force	Bucket / Arm lbf. (kgf)	9535 (4325) / 4112 (1865)			
Drive system	Travel speed	Low / High mph (km/h)	1.8 (2.9) / 3.1 (5.0)			
	Max. traction force	Low speed lbf. (kgf)	9747 (4420)			
	Tumbler distance	ft. in. (mm)	5'7.3" (1710)			
	Crawler length	ft. in. (mm)	7'1.6" (2175)			
	Shoe width	ft. in. (mm)	1'1.8" (350)			
	Ground contact pressure	Rubber Canopy / Cab	psi (kPa)	4.53 (31.2) / 4.68 (32.3)	4.70 (32.4) / 4.86 (33.5)	4.87 (33.6) / 5.02 (34.6)
		Steel Canopy / Cab	psi (kPa)	4.61 (31.8) / 4.76 (32.8)	4.78 (33.0) / 4.93 (34.0)	4.95 (34.1) / 5.10 (35.2)
Swing system	Unit swing speed	rpm	9.2			
	Boom swing angle	Left / Right degree	70 / 55			
Blade	Dimensions	Width	ft. in. (mm)	5'6.9" (1700)	5'10.9" (1800)	
		Height	ft. in. (mm)	1'1.8" (350)	1'3.2" (385)	
	Max. lift above ground	ft. in. (mm)	1'3.7" (400)	1'4.5" (420)	1'4.9" (430)	
	Max. drop below ground	ft. in. (mm)	1'3.9" (405)	1'8.1" (510)	1'8.9" (530)	
	Angle	Left / Right	degree	-	25 / 25	
Tilt		degree	-	10 / 10		
Hydraulic oil (Reservoir / System)		gal (ℓ)	11.1 (42) / 19.6 (74)			
Fuel reservoir		gal (ℓ)	16.9 (64)			
Operating weight (Including operator's weight @ 175 lbs.)	Rubber Canopy / Cab	lbs. (kg)	9195 (4170) / 9500 (4310)	9545 (4330) / 9855 (4470)	9900 (4490) / 10210 (4630)	
	Steel Canopy / Cab	lbs. (kg)	9350 (4240) / 9655 (4380)	9700 (4400) / 10010 (4540)	10050 (4560) / 10360 (4700)	

* OPG (TOP Guard, Level I) in accordance with ISO10262 is equivalent in definition to FOPS (Falling Object Protective Structure).

The company reserves the right to change the above specifications without notice. This brochure is for descriptive purposes only. Please contact your local Kubota dealer for warranty information. For your safety, Kubota strongly recommends the use of a Rollover Protective Structure (ROPS) and seat belt for almost all applications.

DIMENSIONS

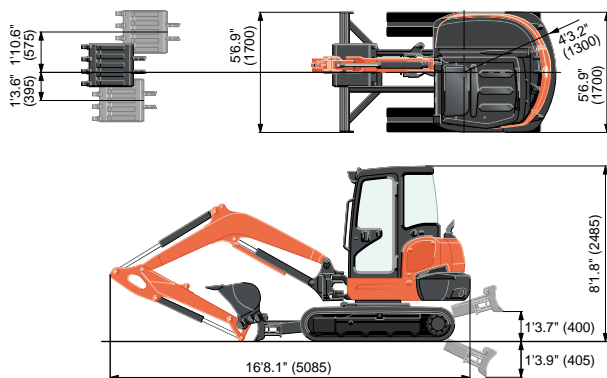

6-in-1 Blade

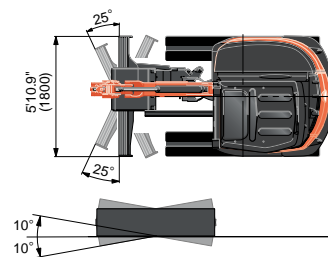

Angle Blade

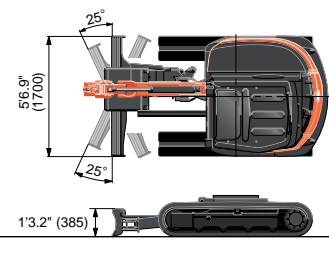

Unit: ft. in. (mm)

©2013 Kubota Corporation



KUBOTA TRACTOR CORPORATION

Kubota Tractor Corporation, 3401 Del Amo Boulevard, Torrance CA 90503
 Western Division: 1175 S. Guild Ave., Lodi, CA 95240 Tel (209) 334-9910
 Central Division: 14855 FAA Boulevard, Fort Worth, TX 76155 Tel (817) 571-0900
 Northern Division: 6300 at One Kubota Way, Groveport, OH 43125 Tel (614) 835-1100
 Southeast Division: 1025 Northbrook Parkway, Suwanee, GA 30024 Tel (770) 995-8855

Visit our web site at: www.kubota.com

