



For Earth, For Life
Kubota

TLB

**KUBOTA DIESEL TRACTOR
B26/L47/M62**

Equipped with performance-matched loader and backhoe, these workhorse tractors bring professional results to a wide range of landscaping, construction, and contracting jobs.



One TLB that does it all, from loading



Here's the utility machine you've been waiting for. One machine that can do the work of three. It's a compact, high-performance tractor-loader-backhoe. An efficient front loader that can also do pallet fork and other implement work. And a backhoe with outstanding digging capacity and digging depth.

Designed and built for independent contractors, landscapers, and rental services, the Kubota B26, L47 and M62 are high performance tractors that offer the high level of performance you need to ensure professional results for every job you do.

The Kubota B26, L47 and M62 are single versatile, compact, highly mobile machines that let you do all the jobs that you need a tractor, front loader and backhoe to do.

And do them all with power, speed, and efficiency.

ng to digging and a whole lot more.



KUBOTA DIESEL TRACTOR
B26/L47/M62

The M62's powerful 63HP engine and performance-matched loader and backhoe offer professional results on everything from landscaping jobs to construction sites.

M62

- Engine gross horsepower: 63.0 HP*
- PTO horsepower: 46.0 HP
- Front loader: 3960 lbs. lift capacity
- Backhoe: 169.8 in. max. digging depth
- Operating weight: 8925 lbs.
- Transmission: HST Plus (6 range)
- Panel: Side IntelliPanel™
- 3-point hitch: category I & II (optional)



Sporting an HST Plus transmission and packed with power, the L47 tractor/loader/backhoe is ideal for rental users, contractors, landscapers and homeowners seeking professional results.

L47

- Engine gross horsepower: 47.1 HP*
- PTO horsepower: 33.0 HP
- Front loader: 2848 lbs. lift capacity
- Backhoe: 121 in. max. digging depth
- Operating weight: 7205 lbs.
- Transmission: HST Plus (6 range)
- Panel: Side IntelliPanel™
- 3-point hitch: category I (optional)



Kubota's innovative compact tractor/loader/backhoe offers greater power, versatility, and durability with it's integrated loader and quick detach backhoe.

B26

- Engine gross horsepower: 24.3HP HP*
- PTO horsepower: 19.5 HP
- Front loader: 1102 lbs. lift capacity
- Backhoe: 99.8 in. max. digging depth
- Operating weight: 4001 lbs.
- Transmission: HST (3 range)
- Panel: Front type
- 3-point hitch: category I (optional)



*SAE J1995

FUNCTION CHART

Functions	B26	L47	M62	
Loader	Hydraulic Circuit-switching Lever	N/A	Std (on deck)	
	Throttle-up Switch	N/A	Std	
	Slanted Boom Design	Std	Std	
	Boom Stopper (Meets Osha1926.600)	N/A	Std	
	Bucket Level Indicator	Std	Std	
	Auto Leveling Valve	N/A (Std. Mech. spill guard)	Std	Std
	Mechanical 2-lever Quick Coupler	Std	Std	Std
	Hydraulic 2-lever Quick Coupler	N/A	Opt	Opt
	3rd Function Valve	Opt	Opt	Opt
	Front Guald	Std	Std	Std
	Integrated Main Frame	Std	Std	Std
Backhoe (If equipped)	Quick Coupler	Opt (TLB original)	Opt (Compatible with MB)	
	Remote Hydraulic Valve	Op	Opt	
	Stabilizer Guard	N/A	Opt	
	Reversible Seat	Std	Std	
	Curved Backhoe Boom	Std	Std	
	Thumb Bracket	Std	Std	
	Flip-over Stabilizer Pad	Std	Std	
	Rubber Stabilizer Pad	Opt	Opt	
	Quick-mount Attach/detach	Std	Std	
	Backhoe Crawling Mode	N/A	Std	
Tractor	Hydraulic Independent PTO	Std	Std	
	3-point Hitch	Opt (Cat.I)	Opt (Cat.I)	
	3-point Hitch Storage	Std	Opt	
	IntelliPanel™	N/A (Front mount panel)	Std (Side mount)	
	Auto Throttle Advance	N/A	Std	
	Hydro Dual Speed (H-ds)	N/A	Std	
	Hst Response Control	N/A	Std	
	Stall Guard Plus And Auto H-ds	N/A	Std	
	Slanted Bonnet Design	Std	Std	
	Horn	Opt	Std	
	Back Buzzer	Opt	Std	
	Head Light / Work Light	Front 2, Rear 2 (Opt. F2, R2)	Front 2, Rear 2 (Opt. F2, R2)	
	Four-wheel Drive	Std	Std	
	Spark Arrestor	Std	-	
	DPF Muffler	-	Std	
	Tilt Handle	Std	Std	
	ROPS/FOPS	Std	Std (meets OSHA1926 1001/1003)	
	Seat Belt	Std	Std	
	Auxiliary Hydraulic Valve	Opt	Opt	
	Drawbar	Opt	Opt	
Differential Lock	Std	Std		
Parking Brake	Std	Std		

Kubota Quality

Top to bottom, front to back, and inside and out, Kubota's B26, L47 and M62 TLBs are engineered for quality. These TLB incorporate the best of Kubota's advanced technology in every detail and function to ensure both superior performance and supreme operator comfort. No matter how you measure quality, the TLB Series delivers.



Original engines

Powerful yet clean, Kubota's new engines feature a Common Rail direct-injection system* that reduces emissions and increases fuel economy while maintaining high levels of power and torque. These reliable engines also boast a Diesel Particulate Filter (DPF)* and Exhaust Gas Recirculation system (EGR)*. Put it all together and you get greater fuel savings as well as a certified Tier 4 Final emissions regulations engine.

**L47/M62 models.*

HST Plus (M62/L47)

Tackle any task with ease and efficiency. With extraordinary precision, HST Plus's automated control of both the HST pump and drive motor gives you optimal performance, regardless of the task, working conditions, or operator expertise.

- Auto Throttle Advance
- Hydro Dual Speed (H-DS)
- HST Response Control
- Stall Guard Plus and Auto H-DS



IntelliPanel™ (M62/L47)

The large, easy to read LCD panel provides all of the vital information you need to keep your TLB in peak working condition for maximum productivity. Indicators, displays, and sensor messages include current working status, engine conditions, fuel and oil warning signals, and a variety of maintenance indicators, so you'll always know how the tractor is functioning and when you need to refuel or perform maintenance.



FRONT LOADER

Even the most demanding loading tasks are no match for Kubota's performance-matched front loaders. With excellent performance, superior versatility and better operability, these front loaders are ready to save you time and effort on every job you do.



**2 lever quick coupler
attachments**



Hydraulic circuit-switching lever (M62/L47)

The lever re-directs the hydraulic oil flow when the backhoe is not in use. Instead of going to the backhoe circuits, the flow returns to the tank, thus reducing hydraulic heat build up resulting from a continuous use of hydraulic front attachments. On the M62, the lever is mounted on the deck for easy access.

Throttle-up switch (M62/L47)

When you need extra power and speed for loader work but don't want to move faster, reach for the throttle-up switch. It increases engine speed (rpm) without increasing travel speed. It also enhances fuel efficiency.

Mechanical 2-lever quick coupler (standard)

Hydraulic 2-lever quick coupler (optional) (M62/L47)

Kubota's 2-lever quick coupler lets you quickly and easily attach and detach front implements. With the optional hydraulic 2-lever quick coupler, you won't even need to leave your seat. Simply press two buttons to release the levers, back away from the now-detached implement, move into the next implement, and press the buttons to re-engage the levers. Changing implements couldn't be easier!



Max. lifting height

B26: 94.5 in. (2400 mm)

L47: 113.9 in. (2893 mm)

M62: 126.1 in. (3203 mm)



BACKHOE

More than just a productive front loader, more than just a powerful tractor, this versatile machine is also a highly efficient backhoe that lets you dig deeper and reach farther to power through even the toughest backhoe jobs. You'll also dig faster, thanks to a quick-hitch system that makes switching buckets a breeze and four-point quick-mount system that makes quick work of attaching and detaching the backhoe. Add a backhoe crawling mode for efficient repositioning, and you have a versatile TLB that can do it all with speed and efficiency.



Bucket Digging Force

B26: 4210 lbs. (18731 N)
L47: 5825 lbs. (25892 N)
M62: 6572 lbs. (29234 N)

Max digging depth

B26: 99.8 in. (2535 mm)
L47: 121.0 in. (3073 mm)
M62: 169.8 in. (4312 mm)

Flip-over stabilizer pad

Switch from road-use side to steel anchor by simply rotating the unit by hand. No tools needed!

Quick-mount attach/detach

A four-point quick-mount system lets you quickly and easily detach the backhoe. When needed again, the backhoe can be reattached just as quickly and easily.

Quick coupler

The backhoe's quick coupler lets you quickly switch buckets and get back to digging. Especially, Quick Coupler which is attached L47/M62 is compatible with select Kubota compact excavator buckets.



Backhoe crawling mode (M62/L47)

Now you can save time when repositioning during backhoe operations. The backhoe crawling mode lets you creep forward or backward with the touch of a finger while remaining at the backhoe controls. It's so simple, you won't even need to change the seat position!



TRACTOR

Get ready for some fast, mobile, and productive tractor work. The Kubota B26, L47 and M62 are unrivaled in the TLB category, offering the operability of 4-wheel drive, the mobility of a compact size, and productivity that comes from a wide range of standard and optional features.



Independent PTO

Get even more work done by attaching a wide range of PTO-driven implements, including rotary tillers, post hole diggers, snow blowers and rear-mounted mowers. The 540 RPM PTO is hydraulic-independent, letting you engage and disengage the PTO without stopping the tractor.

Category I and II 3-point hitch (optional)

Do even more by attaching any of a wide array of rear-mounted implements to the Category I and II 3-point hitch. Attachment is quick and easy, and the hitch provides astonishing lift capacity. (B26/L47 are Category I only.)



Transporting this workhorse is easy (L47/B26)

Easy and fast. Even with both loader and backhoe attached, the compact B26 and L47 can be loaded on a 10,000-lb. GVWR rated trailer pulled by a 3/4-ton pickup truck, letting you quickly and efficiently move to the next job site. (In most states)

FRONT VIEW



REAR VIEW



B26



B26 TRACTOR SPECIFICATIONS

	Non-road emission std.	EPA Final Tier 4
Engine	Gross power*	24.3 HP (18.1 kw)
	Net power**	23.1 HP (17.2 kw)
	Total displacement	68.5 cu.in. (1123 cm ³)
	No. of cylinders	3
	Rated speeds	2800 rpm
	Air cleaner	Single element
	Max. PTO power	
Fuel tank capacity		8.2 gal (31 liters)
Tire size	Front	23 × 8.5–14 R4 (IND)
	Rear	12.4–16 R4 (IND)
Wheelbase		62.2 in. (1581 mm)
Tread	Front	35.6 in (905 mm)
	Rear	41.3 in (1050 mm)
Weight with loader, backhoe and ROPS/FOPS^{*1)}		4001 lbs (1815 kg) ^{*1)}
Min. turning radius^{*3)}		8.2 ft. (2.5 m)
Rear PTO		Independent, 540 rpm
Power steering		Hydrostatic
Transmission	Type	HST (3 range)
	No. of speeds	Infinite
	Max. traveling speed	11.1 mph (17.8 km/h)
	Range shift lever position	Seat side, left
Brake type		Wet disc
Hydraulic system	Pump capacity	11.1 GPM (42.0 ℓ/min) ^{*2)}
	3-point hitch lift capacity at 24 in. (610 mm) behind lift point	1676 lbs (760 kgf)
	Position control	Standard
3-point hitch (Category I)		Optional
ROPS/FOPS (meets OSHA1926 1001/1003, ISO3471)		4 post, Standard
Others	Hard nose slanted hood	Standard
	Back-up alarm	Optional
	Horn	Optional
	Rear axle differential lock	Standard
	Loader-integrated reinforced frame	Standard
	Reversible seat	Standard
	Tilt steering	Standard
	Deck	Full-floating ISO-mounted flat deck
	Glow plug	Super glow

*SAE J1995 **SAE J1349

*1) With round back loader bucket, 18" backhoe bucket and standard tires.

*2) 6.9 GPM for loader/backhoe, 4.2 GPM for backhoe boom.

*3) Without brake

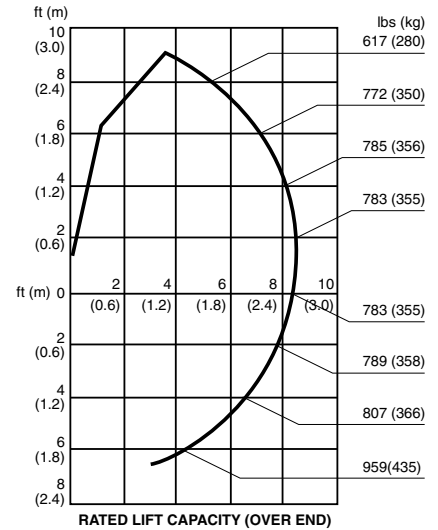
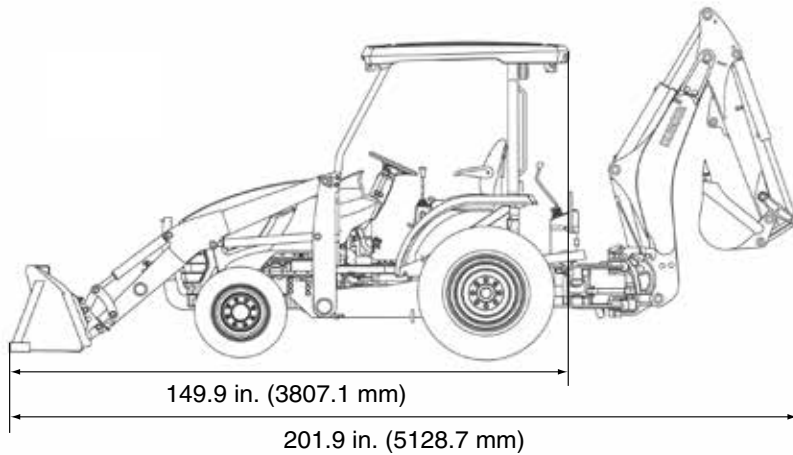

B26 TL500 LOADER SPECIFICATIONS

Lift capacity to max. height at pivot pin:..... 1301 lbs (590 kg)
Breakout force at pivot pin:.....2343 lbs (10417 N)
Control valve:.....One detent float position power beyond circuit
Net weight (approx.):..... 628 lbs (285 kg)
Auto-leveling mechanism:.....Mechanical spill guard
2 lever quick coupler:.....Standard

Operating dimensions:
 A. Maximum lift height to pivot pin94.5 in. (2400 mm)
 B. Clearance with bucket dumped70.0 in. (1778 mm)
 C. Reach at maximum height.....22.3 in. (567 mm)
 D. Maximum dump angle45 deg.
 E. Reach with bucket on ground61.5 in. (1561 mm)
 F. Bucket rollback angle46 deg.
 G. Digging depth 7.0 in. (177 mm)
 H. Overall height in carrying position49.5 in. (1258 mm)

Performance ratings (no load)
Raise to full height: 3.6 sec.
Lowering time: 2.4 sec.
Attachment rollback time: 3.4 sec.
Attachment dumping time: 1.8 sec.

3rd function valves:.....Optional 7.0 GPM

*Tires applied: 23 x 8.50 -14R4 (Front) and 12.4 -16R4 (Rear)

B26 BT820 BACKHOE SPECIFICATIONS

Digging force using bucket cylinder (approx.): 4210 lbs (18731 N)
Digging force using dipperstick cylinder (approx.): 2123 lbs (9444 N)
Trunnion type boom swing mechanism: Two cylinders
Net weight (approx.):..... 1025 lbs (465 kg)

Operating dimensions:
 A. Transport height 89.1 in. (2264 mm)
 B. Stabilizer spread-transport 53.0 in. (1347 mm)
 C. Ground clearance 11.3 in. (287 mm)
 E. Overall width 53.7 in. (1365 mm)
 F. Digging depth, maximum 99.8 in. (2535 mm)
 G. Digging depth, 2ft. flat bottom 98.3 in. (2498 mm)
 H. Digging depth, 8ft. flat bottom 77.0 in. (1957 mm)
 J. Operating height, fully raised129.8 in. (3298 mm)
 K. Loading height 77.3 in. (1963 mm)
 L. Loading reach 52.1 in. (1324 mm)
 M. Reach from swing pivot133.9 in. (3400 mm)
 N. Swing pivot to rear axle center line 33.7 in. (855 mm)
 P. Bucket rotation181.2 deg.
 X. Swing arc180 deg.
 R. Stabilizer spread-operating 83.3 in. (2116 mm)
 A3. Angle of departure per SAE J1234 20.3 deg.
 U. Leveling angle 10.7 deg

Auxiliary hydraulic valve: Optional 7.0 GPM

*The specifications are taken with KUBOTA's B26 tractor.
 *Tire applied: 23 x 8.50-14 R4 (Front) and 12.4-16 R4 (Rear)

The company reserves the right to change the above specifications without notice. This brochure is for descriptive purposes only. Please contact your local Kubota dealer for warranty information. For your safety, KUBOTA strongly recommends the use of a Rollover Protective Structure (ROPS) and seat belt in almost all applications. For complete operational information, the operator's manual should be consulted.

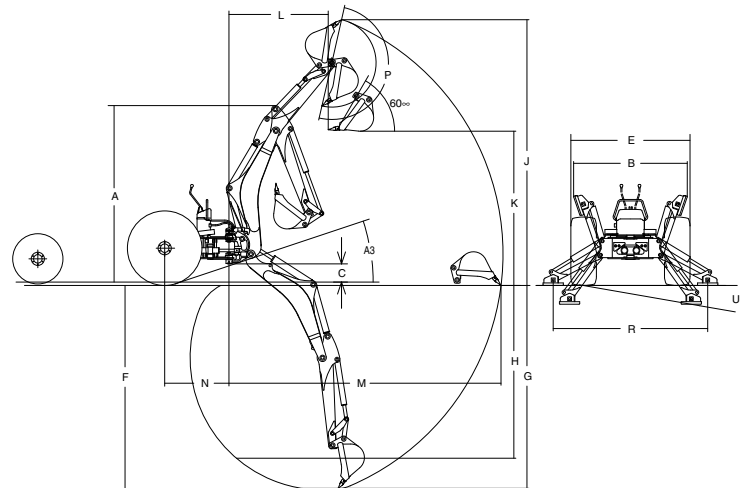
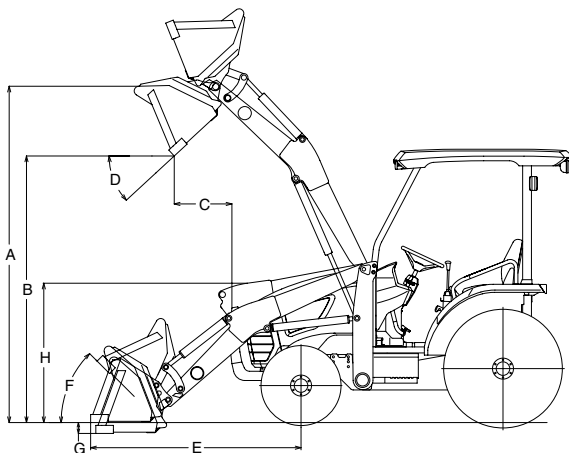

Kubota Tractor Corporation reserves the right to change the stated specifications without notice. This brochure is for descriptive purposes only and reasonable efforts were used to set forth the contained information; some items shown may be optional and some products shown may not be available at all dealerships. Kubota disclaims all representations and warranties, express or implied, or any liability from the use of this brochure. For complete warranty, safety and product information, consult your local Kubota dealer and the operator's manual. Power (HP/KW) and other specifications are based on various standards or recommended practices. For your safety, Kubota strongly recommends the use of a Rollover Protective Structure (ROPS) and seat belt in almost all applications. This brochure is intended for the United States and US territories only. For information regarding Kubota products or services outside these areas, see Kubota Corporation's global web site. Kubota does not provide parts, warranty or service for any Product which is re-sold or retailed in any country other than the country for which the Product(s) were designed or manufactured.

L47



L47 TRACTOR SPECIFICATIONS

	Non-road emission std.	EPA Final Tier 4
Engine	Gross power*	47.1 HP (35.1 kW)
	Net power**	44.7 HP (33.3 kW)
	Total displacement	148.5 cu.in. (2434 cm ³)
	No. of cylinders	4
	Rated speeds	2700 rpm
	Air cleaner	Dual element
	Max. PTO power	
Fuel tank capacity		17.7 gal (67 liters)
Tire size	Front	27 x 10.5-15R4
	Rear	15-19.5R4
Wheelbase		72.5 in (1841 mm)
Tread	Front	45.9 in (1165 mm)
	Rear	56.1 in (1426 mm)
Weight with loader, backhoe and ROPS/FOPS^(*)		7205 lbs (3268 kg)
Min. turning radius^(**)		9.2 ft. (2.8 m)
Rear PTO		Independent, 540 rpm
Power steering		Hydrostatic
Transmission	Type	HST Plus (6 range)
	No. of speeds	Infinite
	Max. traveling speed	14 mph (22.5 km/h)
	Range shift lever position	Seat side, right
Brake type		Wet disc
Hydraulic system	Pump capacity	25.0 GPM (94.9 ℓ/min.) ^(**)
	3-point hitch lift capacity at 24 in. (610 mm) behind lift point	2756 lbs (1250 kg)
	Position control	Standard
3-point hitch (Category I)		Optional
ROPS/FOPS (meets OSHA1926 1001/1003, ISO3471)		4 post, Standard
Others	Hard nose slanted hood	Standard
	Back-up alarm	Standard
	Horn	Standard
	Rear axle differential lock	Standard
	Loader-integrated reinforced frame	Standard
	Reversible seat	Standard
	Tilt steering	Standard
	Deck	Walk-through deck
	Glow plug	Super glow

*SAE J1995 **SAE J1349

^(*)With round back loader bucket, 18" backhoe bucket and standard tires.

^(**)11.8 GPM for loader/backhoe, 6.6 GPM for backhoe boom swing, 6.6 GPM for power steering.

^(**)With brake

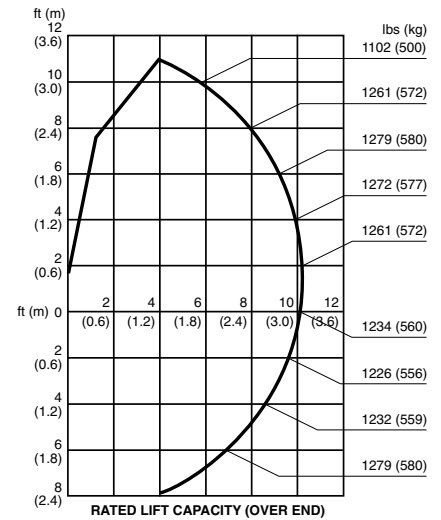
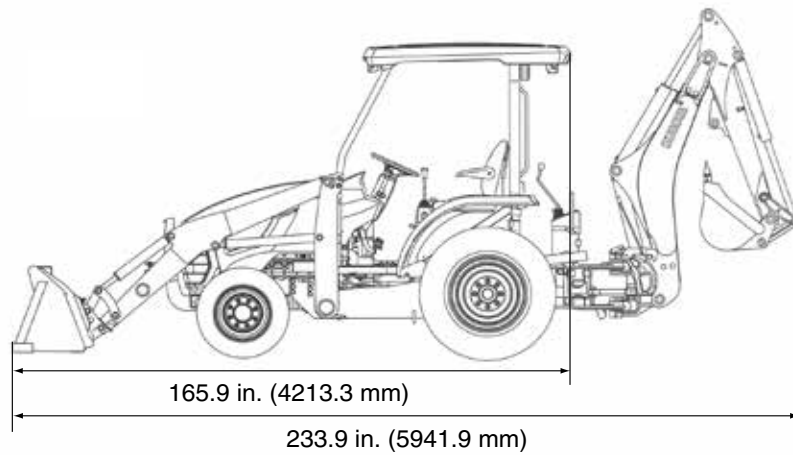

L47 TL1300 LOADER SPECIFICATIONS

Lift capacity to max. height at pivot pin:.....2848 lbs (1292 kg)
Breakout force at pivot pin:.....4531 lbs (20153 N)
Control valve:.....One detent float position power beyond circuit hydraulic dual self-leveling valve
Net weight (approx.):.....960 lbs (435 kg)
Auto-leveling mechanism:.....Standard, Hydraulic
2 lever quick coupler:.....Standard

Operating dimensions:
 A. Maximum lift height to pivot pin113.9 in (2893 mm)
 B. Clearance with bucket dumped90.0 in (2287 mm)
 C. Reach at maximum height.....16.6 in (422 mm)
 D. Maximum dump angle44 deg.
 E. Reach with bucket on ground68.5 in (1739 mm)
 F. Bucket rollback angle48 deg.
 G. Digging depth3.5 in (89 mm)
 H. Overall height in carrying position55.2 in (1402 mm)

Performance ratings (no load self-leveling, max 2900 rpm)

	on	off
Raise to full height:	3.6 sec.	3.2 sec
Lowering time:	5.8 sec.	2.9 sec
Attachment rollback time:	1.9 sec.	1.9 sec
Attachment dumping time:	2.2 sec.	2.2 sec

Boom stopper (meets OSHA1926.600):.....Standard
3rd function valves:.....Optional 11.5 GPM

*Tires applied: 27 x 10.5-15R4 (Front) and 15-19.5R4 (Rear)

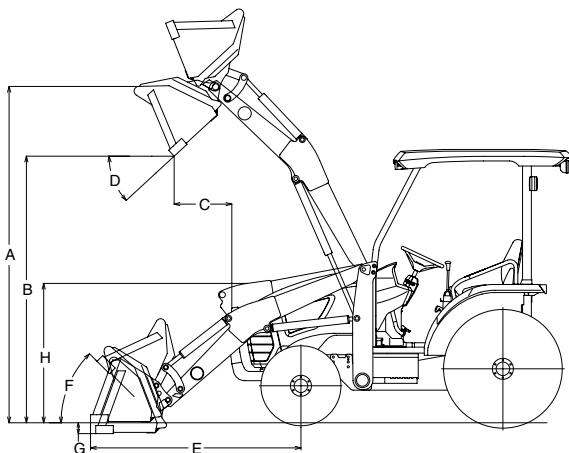

L47 BT1000B BACKHOE SPECIFICATIONS

Digging force using bucket cylinder (approx.): 5825 lbs (25892 N)
Digging force using dipperstick cylinder (approx.): 3779 lbs (16797 N)
Trunnion type boom swing mechanism Two cylinders
Net weight (approx.):1660 lbs (753 kg)

Operating dimensions:
 A. Transport height106.3 in (2700 mm)
 B. Stabilizer spread-transport67.2 in (1707 mm)
 C. Ground clearance12.3 in (312 mm)
 E. Overall width71.2 in (1809 mm)
 F. Digging depth, maximum121.0 in (3073 mm)
 G. Digging depth, 2ft. flat bottom120.0 in (3048 mm)
 H. Digging depth, 8ft. flat bottom102.2 in (2596 mm)
 J. Operating height, fully raised157.2 in (3993 mm)
 K. Loading height92.9 in (2359 mm)
 L. Loading reach54.6 in (1386 mm)
 M. Reach from swing pivot160.9 in (4087 mm)
 N. Swing pivot to rear axle center line38.0 in (965 mm)
 P. Bucket rotation180 deg.
 X. Swing arc180 deg.
 R. Stabilizer spread-operating89.3 in (2268 mm)
 A3. Angle of departure per SAE J123419.2 deg.
 U. Leveling angle10.0 deg.

Auxiliary hydraulic valve: Optional 11.5 GPM

*The specifications are taken with Kubota's L47 tractor.
 *Tire size: 27 x 10.5-15R4 (Front) and 15-19.5R4 (Rear)

The company reserves the right to change the above specifications without notice.
 This brochure is for descriptive purposes only. Please contact your local Kubota dealer for warranty information.
 For your safety, KUBOTA strongly recommends the use of a Rollover Protective Structure (ROPS) and seat belt in almost all applications. For complete operational information, the operator's manual should be consulted.

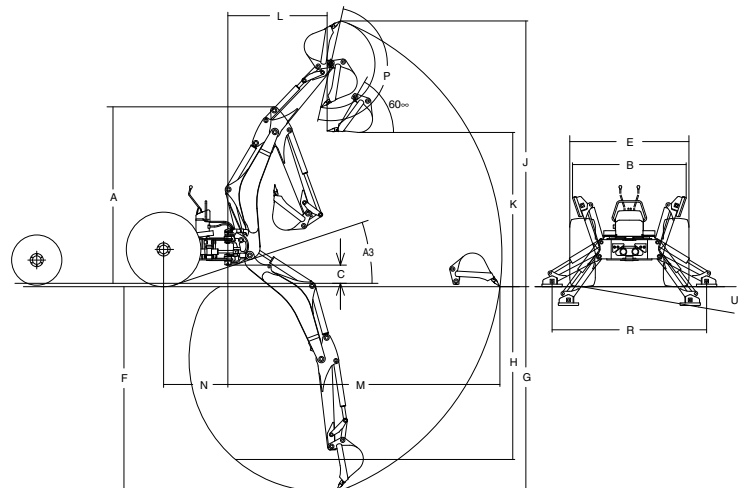

Kubota Tractor Corporation reserves the right to change the stated specifications without notice. This brochure is for descriptive purposes only and reasonable efforts were used to set forth the contained information; some items shown may be optional and some products shown may not be available at all dealerships. Kubota disclaims all representations and warranties, express or implied, or any liability from the use of this brochure. For complete warranty, safety and product information, consult your local Kubota dealer and the operator's manual. Power (HP/KW) and other specifications are based on various standards or recommended practices. For your safety, Kubota strongly recommends the use of a Rollover Protective Structure (ROPS) and seat belt in almost all applications. This brochure is intended for the United States and US territories only. For information regarding Kubota products or services outside these areas, see Kubota Corporation's global web site. Kubota does not provide parts, warranty or service for any Product which is re-sold or retailed in any country other than the country for which the Product(s) were designed or manufactured.

M62



M62 TRACTOR SPECIFICATIONS

	Non-road emission std.	EPA Final Tier 4
Engine	Gross power*	63.0 HP (47.0 kw)
	Net power**	59.1 HP (44.1 kw)
	Total displacement	148.5 cu.in. (2434 cm ³)
	No. of cylinders	4
	Rated speeds	2700 rpm
	Air cleaner	Dual element
	Max. PTO power	
Fuel tank capacity		17.7 gal (67 liters)
Tire size	Front	10 × 16.5–R4
	Rear	17.5L–24 R4
Wheelbase		80.7 in. (2050 mm)
Tread	Front	56.7 in (1440 mm)
	Rear	57.6 in (1462 mm)
Weight with loader, backhoe and ROPS/FOPS^{*1)}		8925 lbs (4048 kg) ^{*1)}
Min. turning radius^{*2)}		10.8 ft. (3.3 m)
Rear PTO		Independent, 540 rpm
Power steering		Hydrostatic
Transmission	Type	HST PLUS (6 range)
	No. of speeds	Infinite
	Max. traveling speed	15.5 mph (24.9 km/h)
	Range shift lever position	Seat side, right
Brake type		Wet disc
Hydraulic system	Pump capacity	30.9 GPM (116.9 ℓ/min) ^{*2)}
	3-point hitch lift capacity at 24 in. (610 mm) behind lift point	2756 lbs (1250 kg)
	Position control	Standard
3-point hitch (Category I)		Optional
ROPS/FOPS (meets OSHA1926 1001/1003, ISO3471)		4 post, Standard
Others	Hard nose slanted hood	Standard
	Back-up alarm	Standard
	Horn	Standard
	Rear axle differential lock	Standard
	Loader-integrated reinforced frame	Standard
	Reversible seat	Standard
	Tilt steering	Standard
	Deck	Walk-through deck
	Glow plug	Super glow

*SAE J1995 **SAE J1349

^{*1)}With round back loader bucket, 18" backhoe bucket and standard tires.

^{*2)}11.8 GPM for loader/backhoe, 6.6 GPM for backhoe boom swing, 6.6 GPM for power steering.

^{*3)}With brake

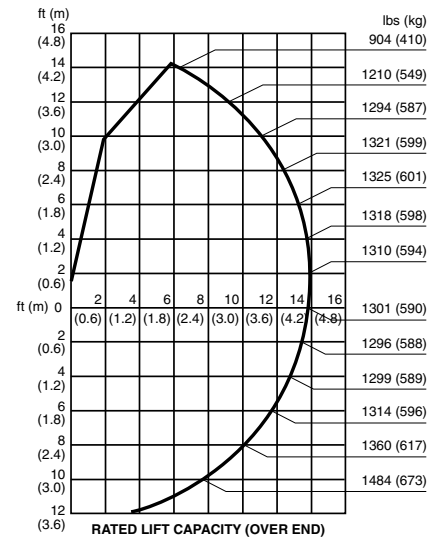
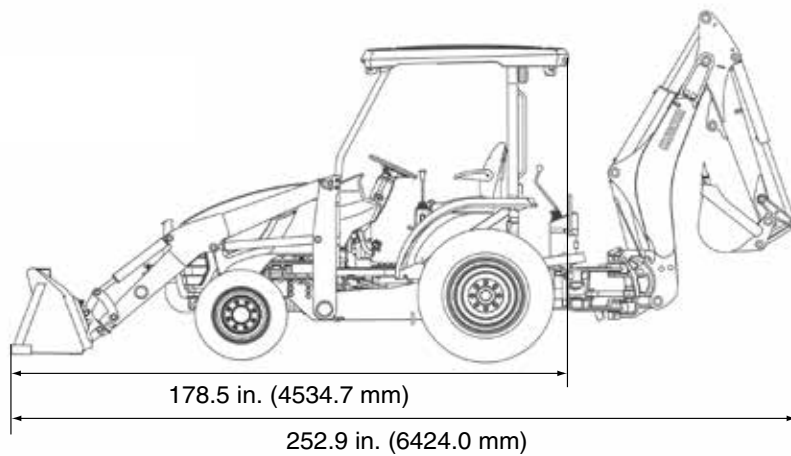

M62 TL1800 LOADER SPECIFICATIONS

Lift capacity to max. height at pivot pin:..... 3960 lbs (1796 kg)
Breakout force at pivot pin:..... 5992 lbs (26654 N)
Control valve:..... One detent float position
 power beyond circuit
 hydraulic dual self-leveling valve
Net weight (approx.):..... 1169 lbs (530 kg)
Auto-leveling mechanism:..... Standard, Hydraulic
2 lever quick coupler:..... Standard

Operating dimensions:
 A. Maximum lift height to pivot pin 126.1 in. (3203 mm)
 B. Clearance with bucket dumped 95.0 in. (2412 mm)
 C. Reach at maximum height 24.1 in. (612 mm)
 D. Maximum dump angle 43 deg.
 E. Reach with bucket on ground 71.7 in. (1821 mm)
 F. Bucket rollback angle 45 deg.
 G. Digging depth 2.7 in. (69 mm)
 H. Overall height in carrying position 63.0 in. (1600 mm)

Performance ratings (no load self-leveling, max 2900 rpm)

	on	off
Raise to full height:	4.2 sec.	3.9 sec
Lowering time:	4.3 sec.	3.1 sec
Attachment rollback time:	2.4 sec.	2.4 sec
Attachment dumping time:	2.4 sec.	2.4 sec

Boom stopper (meets OSHA1926.600):..... Standard
3rd function valves:..... Optional 16.0 GPM

*Tires applied: 10 × 16.5-15R4 (Front) and 17.5L-24R4 (Rear)

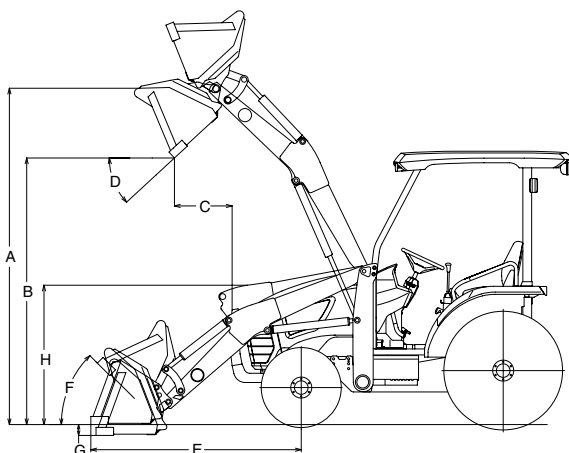

M62 BT1400 BACKHOE SPECIFICATIONS

Digging force using bucket cylinder (approx.): 6572 lbs (29234 N)
Digging force using dipperstick cylinder (approx.): 4657 lbs (20715 N)
Trunnion type boom swing mechanism Two cylinders
Net weight (approx.): 2160 lbs (980 kg)

Operating dimensions:
 A. Transport height 136.0 in. (3445 mm)
 B. Stabilizer spread-transport 67.2 in. (1707 mm)
 C. Ground clearance 13.8 in. (352 mm)
 E. Overall width 75.0 in. (1905 mm)
 F. Digging depth, maximum 169.8 in. (4312 mm)
 G. Digging depth, 2ft. flat bottom 168.4 in. (4277 mm)
 H. Digging depth, 8ft. flat bottom 154.7 in. (3929 mm)
 J. Operating height, fully raised 202.9 in. (5153 mm)
 K. Loading height 130.9 in. (3325 mm)
 L. Loading reach 82.0 in. (2083 mm)
 M. Reach from swing pivot 211.1 in. (5361 mm)
 N. Swing pivot to rear axle center line 39.7 in. (1008 mm)
 P. Bucket rotation 180 deg.
 X. Swing arc 180 deg.
 R. Stabilizer spread-operating 89.3 in. (2268 mm)
 A3. Angle of departure per SAE J1234 20.4 deg.
 U. Leveling angle 10.0 deg.

Auxiliary hydraulic valve: Optional 16.0 GPM

*The specifications are taken with Kubota's M62 tractor.
 *Tire size: 10-16.5 R4 (Front) and 17.5L-24 R4 (Rear)

The company reserves the right to change the above specifications without notice.
 This brochure is for descriptive purposes only. Please contact your local Kubota dealer for warranty information.
 For your safety, KUBOTA strongly recommends the use of a Rollover Protective Structure (ROPS) and seat belt in almost all applications. For complete operational information, the operator's manual should be consulted.

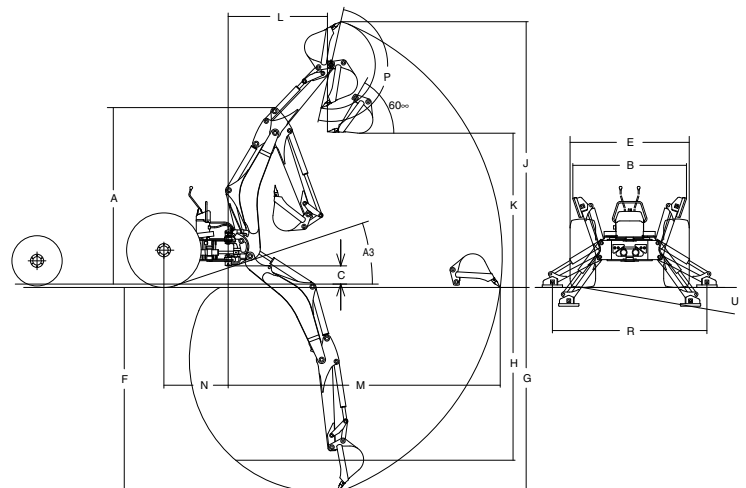

VERSATILE APPLICATIONS

Kubota TLB series provide wide range operations for professionals.



Rotary Cutter



Pallet Forks



Box Blade



Power Box Rake



Sweeper



4-in-1 Bucket



2-lever Quick Coupler Attachments

NOTE: Some TLBs in this brochure are shown with optional accessories.

©2017 Kubota Corporation

Kubota®

KUBOTA TRACTOR CORPORATION

1000 Kubota Drive, Grapevine, TX 76051 Tel 888-4 KUBOTA

Visit our web site at: kubotaUSA.com

